

WC930222

DAWLEY WHITE STEEL DOUBLE DOOR CABINET



ILLUSTRATED

WC930222 DAWLEY WHITE STEEL
DOUBLE DOOR CABINET

CONFIGURATIONS

N/A

MATERIAL

Carcass: Mild Steel

Door Front: Mild Steel, MDF, 3mm mirror
glass

Pin Handle: Chrome plated zinc

Shelf Material: Mild Steel

COLOUR/FINISH

External: Steel with white powder coated
finish

Internal: Steel with white powder coated
finish

WEIGHT

19.8lb (9kg)

PACKAGING

White box with colour label

FREQUENTLY USED APPLICATIONS

Residential

Hotels

FEATURES

Two adjustable shelves.

Reversible door with dual pin handle holes.

Easy to install Help 'n' Hang system.

100° degree hinges.

CARE AND MAINTENANCE

Clean surfaces with a damp cloth and wipe
dry using a soft cloth.

Do not use chemical or abrasive cleaners as
these may damage the surface finish.

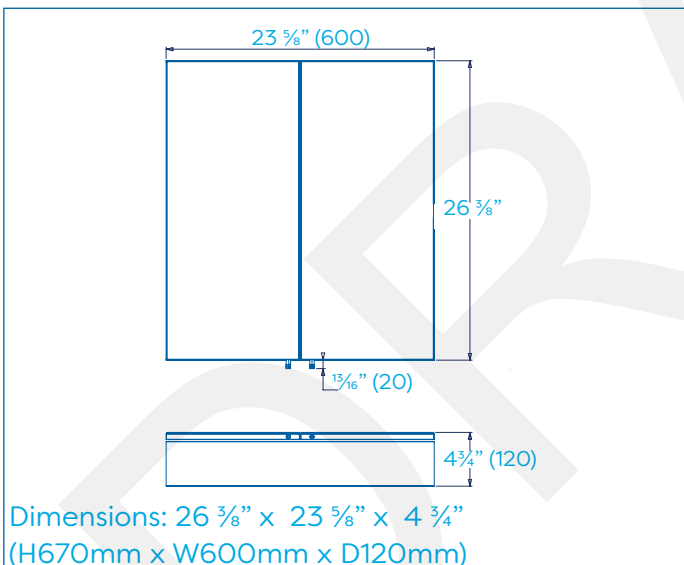

GUARANTEE

Consumer Statutory Rights Apply

Tel: +44 (0) 1264 365881
Fax: +44 (0) 1264 356437
Email: info@croydex.co.uk
Web: www.croydex.com

Printed material, designs and packaging are
protected by copyright and design right.

Date Created:22/12/21 | REV 002